

Tektronix Logic Analyzers

► TLA7PG2 Pattern Generator Module



Breakthrough Solutions for Real-time Digital Systems Analysis

Hardware and software engineers need the ability to generate digital stimuli to simulate infrequently encountered test conditions in hardware design and software program testing. A pattern generator enables you to perform functional verification, debugging and stress testing for system hardware design. This multi-channel, programmable pattern generator module with sequential control stimulates a prototype with data from a simulator for extended analysis. The pattern generator is ideal for designing systems where surrounding boards, ICs or buses that normally provide digital signals to the device under test are missing. With the pattern generator, you can place a circuit in a desired state, operate it at full speed, or single-step it through a series of states.

The TLA7PG2 features 64 channels and supports up to a 268 MHz clock rate for data output. The TLA7PG2 is made compatible with numerous voltage levels and technologies through the use of external pattern generator probes.

The TLA700 Series logic analyzers capture waveform data in a form that can be read by SynaptiCAD™ WaveFormer Pro™, VeriLogger Pro, and TestBencher Pro software tools.

SynaptiCAD's tools can convert the logic analyzer waveform data into stimulus vectors for VHDL, Verilog, SPICE, ABEL and pattern generators, including the TLA7PG2. This functionality gives engineers the ability to leverage the work done during the design phase of a product, simplifying the development of a hardware test environment that provides complete test coverage and excellent debug capability.

► Features & Benefits

64 Channel Modules with up to 2 Mb Vector Depth

Up to 268 MHz Clock Rate

Supports TTL/CMOS, ECL, PECL/LVPECL, LVDS, LVC-MOS Standard Logic Levels

Variable Probe for Supporting Variable Voltage Levels and Delay of Two Channels for Functional Verification

Pattern Sequencing Control of Vector Output Allows Flexible Definition of Complex Events

Works with all TLA700 Series Logic Analyzer Mainframes

► Applications

Digital Hardware Verification and Debug

Digital Hardware Simulation and Debug

COMPUTING

COMMUNICATIONS

VIDEO

Tektronix Logic Analyzers

▶ TLA7PG2 Pattern Generator Module

▶ Characteristics

General

Data Width –

64 Channel full channel mode.
32 Channel half channel mode.

Module “Merging” – Five modules can be “merged” to make up to a 320 channel module. Merged modules exhibit the same depth as the lesser of the 5 individual modules.

Number of Mainframe Slots Required – 2.

Data Rate –

Internal Clock:

0.5 Hz to 134 MHz full channel mode.
1.0 Hz to 268 MHz half channel mode.

External Clock:

DC to 134 MHz full channel mode.
DC to 268 MHz half channel mode.

External Clock Input –

Polarity: positive or negative.
Threshold: –2.56 V to +2.54 V, nominal;
programmable in 20 mV increments.
Sensitivity: < 500 mV_{p-p}.
Impedance: 1 kΩ terminated to ground.

Data Depth –

256 k full channel/512 k half channel.
1 M full channel/2 M half channel (optional).

Pattern Sequencing Characteristics

Blocks – Separate sections of pattern program that are output in a user definable order by the Sequencer. Block pattern depth can be from 40 sequences (full channel mode) or 80 sequences (half channel mode) up to the entire depth of the TLA7PG2. A maximum of 4,000 Blocks may be defined.

Sequencer – A 4,000 line memory that allows the user to pick the output order of individual Blocks. Each line in the sequencer allows the definition of a Block to be output, a Repeat Count for that Block, A Wait For event condition for the Block, the Signal state for that Block (asserted or unasserted), and a Jump If event Condition, with a sequence line to jump to if the condition is satisfied.

Sub-sequences – Up to 50 contiguous lines of the Sequencer memory may be defined as a Sub-sequence. A Sub-sequence can then be treated like a block. (Example: 15 Sequences of Blocks are defined as Sub-sequence A1. Now any line in the Sequencer can output A1. Five calls to Sub-sequence A1 will be flattened out to 75 sequences at run time.)

Jump If – Jumps to the specified sequence if a user defined event is true. The user defined event is a boolean combination of the eight external event input lines and the one-of-four intermodule signals. The user defined event is selectable between level and edge (event going from false to true). One Jump If may be defined for every Block. The Jump If command works at all clock rates, including the maximum half channel mode rate of 268 MHz.

Wait For – Pattern output is paused until the user defined Event is true. One Wait For may be defined for every Block.

Assert Signal – One of the four inter-module signals is selected to be controlled from the pattern generator program. Signals may be asserted and unasserted allowing true interaction with the logic analyzer modules and with other pattern generator modules. Signal action (assert or unassert) may be defined for every Block.

Repeat Count – The sequence is repeated from 1 to 65,536 times. Infinite may also be selected. One Repeat Count may be defined for every block. Note that a repeat value of 10,000 takes one sequence line in memory, not 10,000.

Step – While in Step mode, the TLA7PG2, the user can manually satisfy (i.e., click an icon) Wait For and Jump conditional events. This allows the user to debug the logic flow of the program's sequencing.

Initialization Block – The unconditional Jump command allows the user to implement an equivalent function.

Logic Analyzer/Pattern Generator Connectivity to Simulation Environments

The TLA600 and TLA700 Series logic analyzers capture waveform data in a form that can be read by SynaptiCAD™ WaveFormer Pro™, VeriLogger Pro, and TestBench Pro software tools. SynaptiCAD's tools can convert the logic analyzer waveform data into stimulus vectors for VHDL, Verilog, SPICE, ABEL, and pattern generators including the TLA7PG2.

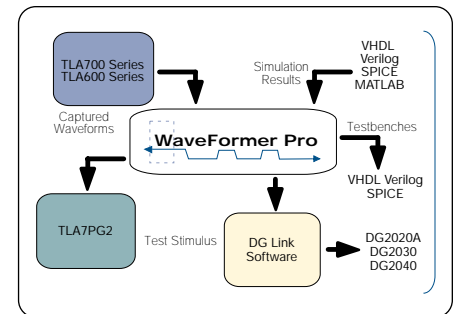

▶ Easily Create TLA7PG2 Stimulus Files.

The TLA7PG2 Pattern Generator stimulus can be created from a mixture of VHDL and Verilog test benches, simulation waveforms, real world data acquired by a logic analyzer, and waveforms created within SynaptiCAD's timing diagram editing environment.

SynaptiCAD's WaveFormer Pro product offers a timing diagram editing environment that enables stimulus to be created using a combination of graphically drawn signals, timing parameters that constrain edges, clock signals, and temporal and Boolean equations for describing complex, quasi-repetitive signal behavior. Advanced operations on signals such as time scaling and shifting, and block copy and pasting of signal behavior over an interval of time are also supported.

Physical Characteristics for TLA7PG2

Dimensions	mm	in.
Height	262	10.3
Width	61	2.4
Depth	381	15
Weight	kg	lb.
Net	3	6.5
Shipping	6.2	13.5

Common to P6470 TTL/CMOS, P6471 ECL, P6473 LVDS, P6474 LVCMOS Probes

Number of Data Outputs –

16 in Full Channel Mode.
8 in Half Channel Mode.

Number of Clock Outputs – 1. (Only one of Clock Output and Strobe Output can be enabled.)

Number of Strobe Outputs – 1. (Only one of Clock Output and Strobe Output can be enabled.)

Clock Output Polarity – Positive.

Strobe Type – RZ only.

Strobe Delay – Zero or Trailing Edge.

P6470 TTL/CMOS Probe

Output Type –

HD74LVC541A for Data Output.
 HD74LVC244A for Clock/Strobe Output.

Output Voltage (nominal, load: 1 M Ω) –

V_{OH}: 2.0 V to 5.5 V, tri-stateable, programmable
 in 25 mV increments.
 V_{OL}: 0 V.

Data Output Skew –

<510 ps typical between all data output pins of all
 modules in the mainframe after inter-module skew
 is adjusted manually.
 <480 ps typical between all data output pins
 of single probe.

Data Output to Strobe Output Delay –

1.7 ns typical when strobe delay set to zero.

Data Output to Clock Output Delay – 2.4 ns typical.

External Clock Input to Clock Output Delay –

Full channel mode: 61.5 ns typical.
 Half channel mode: 61.5 ns typical.

Number of External Event Inputs – 1.

Number of External Inhibit Inputs – 1.

External Inhibit Input to Output Enable Delay –

34 ns typical for Data Output.

External Inhibit Input to Output Disable Delay –

86 ns typical for Data Output.

Probe D Data Output to Output Enable Delay –

(for Internal Inhibit) 7 ns typical for Data Output.

Probe D Data Output to Output Disable Delay –

(for Internal Inhibit) 8 ns typical for Data Output.

**External Event Input to Clock Output Setup
 (for inhibit) (event-filter: off) –**

Full channel mode: 1.5 clocks + 150 ns typical.
 Half channel mode: 2 clocks + 150 ns typical.

External Event Input and Inhibit Input –

Input Type: 74LVC14A.
 Minimum Pulse Width: 100 ns.

P6470 TTL/CMOS Probe

Rise/Fall Time (20% to 80%)

Timing values measured using 75 Ω termination
 (internal to probe), 1 M Ω + <1 pF load and V_{OH} set
 to 5.0 V.

Clock/Strobe Output:

Rise:	640 ps typical
Fall:	1.1 ns typical

Data Output:

Rise:	680 ps typical
Fall:	2.9 ns typical

Timing values measured using 75 Ω termination
 (internal to probe), 510 Ω + 51 pF load and V_{OH} set
 to 5.0 V.

Clock/Strobe Output:

Rise:	6.5 ns typical
Fall:	6.3 ns typical

Data Output:

Rise:	5.2 ns typical
Fall:	4.5 ns typical

P6471 ECL Probe

Output Type –

100E151 for data output.
 100EL16 for strobe output.
 100ELO4 for clock output.
 All outputs are unterminated.

Data Output Skew – <170 ps typical between all
 data output pins of all modules in the mainframe
 after inter-module skew is adjusted manually.
 <140 ps typical between all data output pins
 of single probe.

Data Output to Strobe Output Delay – 2.94 ns
 typical when strobe delay set to zero.

Data Output to Clock Output Delay – 780 ps
 typical.

External Clock Input to Clock Output Delay –
 51 ns typical.

Number of External Event Inputs – 2.

External Event Input –

Input Level: ECL.
 Input Type: 10H116.
 Minimum Pulse Width: 50 ns.

**P6471 ECL Probe Rise/Fall Time
 (20% to 80%)**

Timing values measured using 51 Ω to –2.0 V.

Clock Output:

Rise:	320 ps typical
Fall:	330 ps typical

Data Output:

Rise:	1200 ps typical
Fall:	710 ps typical

Strobe Output:

Rise:	290 ps typical
Fall:	270 ps typical

Tektronix Logic Analyzers

► TLA7PG2 Pattern Generator Module

P6472 PECL/LVPECL Probe

Number of Data Outputs – 8 in full channel mode or half channel mode.

Number of Clock Outputs – 1. (only one of clock output and strobe output can be enabled.)

Number of Strobe Outputs – 1. (only one of clock output and strobe output can be enabled.)

Number of External Event Inputs – 2.

Number of External Inhibit Inputs – 0.

Clock Output Polarity – Positive.

Strobe Type – RZ only.

Strobe Delay – Zero or Trailing Edge.

Output Type –

100EP90 for data output.

100EP90 for clock/strobe output.

Rise/Fall Time (20% to 80%) –

Rise:	330 ps typical
-------	----------------

Fall:	970 ps typical
-------	----------------

Output Voltage Level – PECL, LVPECL.

Data Output Skew –

<385 ps between all data output pins of all modules in the mainframe after inter-module skew is adjusted manually.

<370 ps between all data output pins of all probes of a single module.

<340 ps between all data output pins of a single probe.

Data Output to Strobe Output Delay – +2.93 ns when strobe delay set to zero.

Data Output to Clock Output Delay – +1.12 ns.

External Clock Input to Clock Output Delay – 50 ns.

Event Input Voltage Level – PECL, LVPECL.

Input Type – 100EL91, unterminated.

Minimum Pulse Width – 150 ns.

P6473 LVDS Probe

Number of External Event Inputs – 1.

Number of External Inhibit Inputs – 1.

Output Type –

LVDS (TIA/EIA-644 compatible) for data output.

LVDS (TIA/EIA-644 compatible) for clock/strobe output.

Rise/Fall Time (20% to 80%) –

Rise:	910 ps typical
-------	----------------

Fall:	750 ps typical
-------	----------------

Data Output Skew –

<365 ps between all data output pins of all modules in the mainframe after inter-module skew is adjusted manually.

<350 ps between all data output pins of all probes of a single module.

<320 ps between all data output pins of a single probe.

Data Output to Strobe Output Delay –

–280 ps when strobe delay set to zero.

Data Output to Clock Output Delay – 1.2 ns.

External Clock Input to Clock Output Delay – 55 ns.

External Inhibit to Output Enable Delay – 9 ns for data output.

External Inhibit Input to Output Disable Delay – 12 ns for data output.

Probe D Data Output to Output Enable Delay – 2 ns for data output.

Probe D Data Output to Output Disable Delay – 5 ns for data output.

External Event Input to Clock Output Setup –

Full Channel Mode: 1.5 Clocks + 180 ns.

Half Channel Mode: 2 Clocks + 180 ns.

External Event Input and Inhibit Input –

Input Type: LVDS, positive true.

Minimum Pulse Width: 150 ns.

P6474 LVCMOS Probe

Number of External Event Inputs – 2.

Number of External Inhibit Inputs – 1.

Output Type – 74AVC16244 for data, clock, strobe outputs.

Series Terminator Resistor – 75 Ω standard. 43, 100, and 150 Ω optional.

Rise/Fall Time (20% to 80%) –

Load: 1 M Ω + <1 pF

Rise:	1.2 ns
-------	--------

Fall:	610 ps typical
-------	----------------

Load: 512 Ω + 50 pF

Rise:	3.4 ns
-------	--------

Fall:	3.2 ns
-------	--------

Output Voltage Level – 1.2 V to 3.3 V, 25 mV step, into 1 M Ω .

Data Output Skew –

<590 ps between all data output pins of all modules in the mainframe after inter-module skew is adjusted manually.

<500 ps between all data output pins of all probes of a single module.

<460 ps between all data output pins of a single probe.

Data Output to Strobe Output Delay –

460 ps when strobe delay set to zero.

Data Output to Clock Output Delay – 1.84 ns.

External Clock Input to Clock Output Delay – 55 ns.

External Inhibit to Output Enable Delay – 36 ns for data output.

External Inhibit Input to Output Disable Delay – 18 ns for data output.

Probe D Data Output to Output Enable Delay – 6 ns for data output.

Probe D Data Output to Output Disable Delay – 7 ns for data output.

External Event Input to Clock Output Setup –

Full Channel Mode: 1.5 clocks + 180 ns.

Half Channel Mode: 2 clocks + 180 ns.

External Event Input and Inhibit Input –

74AVC16244, Positive True, 1 k Ω to ground.

The Vcc of the input receiver is variable and is the same as the output driver.

Minimum Pulse Width: 150 ns.

P6470 Probe Cable Length – 1.6 m (5 ft.).

P6471 Probe Cable Length – 1.6 m (5 ft.).

P6472 Probe Cable Length – 1.6 m (5 ft.).

P6473 Probe Cable Length – 1.6 m (5 ft.).

P6474 Probe Cable Length – 1.6 m (5 ft.).

P6475 Variable Probe

Rise/Fall Time (20% to 80%) –

Load: 1 M Ω + <1 pF

Rise:	550 ps
Fall:	640 ps

Load: 512 Ω +50 pF

Rise:	430 ps
Fall:	510 ps

Output Voltage Level –

V_{OL} : –3 V to 6.5 V, 10 mV step, into 1 M Ω .

V_{OH} : –2.5 V to +7 V, 10 mV step, into 1 M Ω .

Output Voltage Swing – 250 mV_{p-p} to 9 V_{p-p}.

Output Voltage Control –

Ch. 0 to Ch. 5: Common.

Ch. 6 to Ch. 7, clock: Independent.

Accuracy – \pm 3% of value \pm 0.1 V.

Delay Channels – Ch. 6 and Ch. 7 (Independent).

Delay Time – 0 ns to 50 ns with reference to Ch. 0.

Ch. 6 Output Modes –

Normal.

Ch. 6 OR Ch. 7.

Ch. 6 AND Ch. 7.

Ch. 6 OR (NOT Ch. 7).

Ch. 6 AND (NOT Ch. 7).

Delay Accuracy – \pm (3% of Delay Time) \pm 0.8 ns (to Ch. 0).

(At maximum slew rate setting).

Slew Rate Control – 0.5 V/ns to 2.5 V/ns, 100 mV/ns step.

Data Output Skew –

<295 ps between all data output pins of all modules in the mainframe after inter-module skew is adjusted manually.

<280 ps between all data output pins of all probes of a single module.

<250 ps between all data output pins of a single probe.

Data Output to Clock Output Delay – 940 ps.

External Clock Input to Clock Output Delay – 62 ns.

Number of External Event Inputs – 2.

Number of External Inhibit Inputs – 1.

External Inhibit to Output Enable Delay – 30 ns for data output.

External Inhibit Input to Output Disable Delay – 28 ns for data output.

Probe D Data Output to Output Enable Delay – –100 ps for data output.

Probe D Data Output to Output Disable Delay – –4.4 ns for data output.

External Event Input to Clock Output Setup –

Full Channel Mode: 1.5 Clocks + 180 ns.

Half Channel Mode: 2 Clocks + 180 ns.

External Event Input and Inhibit Input –

Polarity: Positive True.

Impedance: 1 k Ω to ground.

Threshold Level: –2.5 V to +2.5 V, Event and Inhibit are independent.

Threshold Resolution: 20 mV.

Minimum Pulse Width: 150 ns.

P6475 Probe Cable Length – 1.6 m (5 ft.).

► Ordering Information

Pattern Generator Module

TLA7PG2 – 64-Channel pattern generator module, 134 MHz data rate, 256 K depth (please select probe option below).

Includes: Four probe cables, user manual, certificate of calibration and one year warranty (return to Tektronix).

Opt. 1C – Add 168 SMT KlipChip™ grabber tips.

Opt. 1M – Increase to 1 M depth.

Opt. 1P – Add four 16-channel P6470 TTL/CMOS probes (each includes two 8-channel leadsets and one 5-channel leadset).

Opt. 2P – Add four 16-channel P6471 ECL probes (each includes two 8-channel leadsets and one 5-channel leadset).

Opt. 3P – Add four 16-channel P6472 PECL probes (each includes one 8-channel leadset and one 5-channel leadset).

Opt. 4P – Add four 8-channel P6473 LVDS probes (each includes two 8-channel leadsets and one 5-channel leadset).

Opt. 5P – Add four 16-channel P6474 LVCMOS probes (each includes two 8-channel leadsets and one 5-channel leadset).

Opt. 6P – Add one 8-channel P6475 Variable probe with 115 V US Std. power plug. (Includes 12 SMB-to-header coax cables).

Opt. 7P – Add one 8-channel P6475 Variable probe with 220 V Euro power plug. (Includes 12 SMB-to-header coax cables).

Opt. 8P – Add one 8-channel P6475 Variable probe with 240 V UK power plug. (Includes 12 SMB-to-header coax cables).

Opt. 9P – Add one 8-channel P6475 Variable probe with 240 V Australian power plug. (Includes 12 SMB-to-header coax cables).

Opt. AP – Add one 8-channel P6475 Variable probe with 240 V N. American power plug. (Includes 12 SMB-to-header coax cables).

Opt. BP – Add one 8-channel P6475 Variable probe with 220 V Swiss power plug. (Includes 12 SMB-to-header coax cables).

Opt. CP – Add one 8-channel P6475 Variable probe with no power plug. (Includes 12 SMB-to-header coax cables).

TLA700 Series Pattern Generator Module(s) Upgrades

You can increase the memory depth of most existing TLA700 Series pattern generator modules. You can also install a TLA7PG2 pattern generator module into and existing TLA714/715/720/721/7XM mainframe. Please refer to the TLA Family Upgrade Guide for further details.

Tektronix Logic Analyzers

▶ TLA7PG2 Pattern Generator Module

TLA7PG2 Pattern Generator Probes

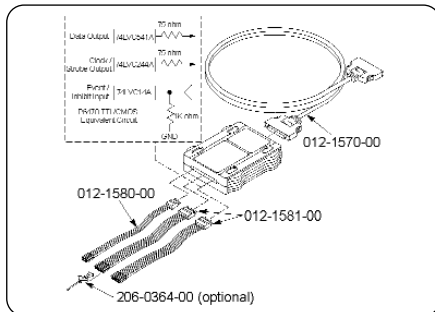

▶ **P6470.**

16-Channel TTL/CMOS Probe and Accessories for TLA7PG2 Pattern Generator Module – Order P6470.

Part Number	Description
012-1581-00	2 each – 8-Channel leadsets
012-1580-00	1 each – 5-Channel leadset
012-1570-00	(optional – std. with TLA7PG2 module) probe cable
071-1017-01	Pattern Generator Probe User Manual

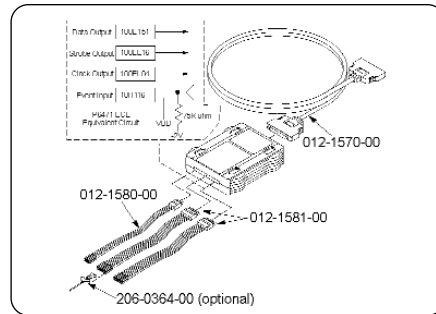

▶ **P6471.**

16-Channel ECL Probe and Accessories for TLA7PG2 Pattern Generator Module – Order P6471.

Part Number	Description
012-1581-00	2 each – 8-Channel leadsets
012-1580-00	1 each – 5-Channel leadset
012-1570-00	(optional – std. with TLA7PG2 module) probe cable
071-1017-01	Pattern Generator Probe User Manual

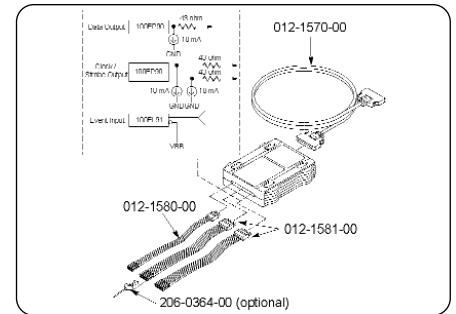

▶ **P6472.**

8-Channel PECL/LVPECL Probe and Accessories for TLA7PG2 Pattern Generator Module – Order P6472.

Part Number	Description
012-1581-00	1 each – 8-Channel leadset
012-1580-00	1 each – 5-Channel leadset
012-1570-00	(optional – std. with TLA7PG2 module) probe cable
071-1017-01	Pattern Generator Probe User Manual

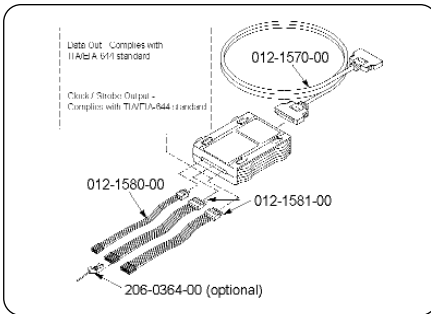

► P6473.

16-Channel LVDS Probe and Accessories for TLA7PG2 Pattern Generator Module – Order P6473.

Part Number	Description
012-1581-00	2 each – 8-Channel leadsets
012-1580-00	1 each – 5-Channel leadset
012-1570-00	(optional – std. with TLA7PG2 module) probe cable
071-1017-01	Pattern Generator Probe User Manual

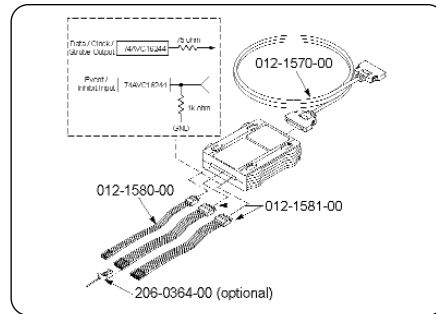

► P6474.

16-Channel LVCMOS Probe and Accessories for TLA7PG2 Pattern Generator Module – Order P6474.

Part Number	Description
012-1581-00	2 each – 8-Channel leadsets
012-1580-00	1 each – 5-Channel leadset
012-1570-00	(optional – std. with TLA7PG2 module) probe cable
071-1017-01	Pattern Generator Probe User Manual

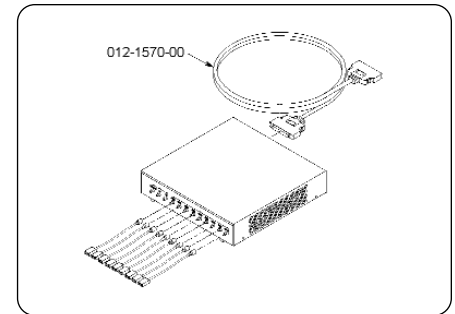

► P6475.

8-Channel Variable Probe and Accessories for TLA7PG2 Pattern Generator Module – Order P6475.

Part Number	Description
012-1504-00	SMB-to-header Coaxial Cable Set
012-1570-00	(optional – std. With TLA7PG2 module) Probe Cable
071-1017-01	Pattern Generator Probe User Manual
012-A224-00	Time Alignment Cable for use with P6470/P6473/P6474

► TLA Family Service Options

	TLA6XX	TLA715/721	TLA7XM	TLA7AXX	TLA7NX/PX/QX	TLA7PG2	TLA7DX/EX
Opt. IN		X	X	X	X	X	X
Opt. R3	X	X	X	X	X	X	X
Opt. R5	X	X	X	X	X	X	X
Opt. S1		X	X				
Opt. S3		X	X				
Opt. C3	X	X		X	X	X	X
Opt. C5	X	X		X	X	X	X
Opt. D1	X	X		X	X	X	X
Opt. D3	X	X		X	X	X	X
Opt. D5	X	X		X	X	X	X

Tektronix Logic Analyzers

▶ TLA7PG2 Pattern Generator Module

TLA Family Service Options

Opt. IN – Product installation service (on-site configuration and user familiarization; excluding network integration).

Opt. R3 – Extends depot repair warranty service period to three years.

Opt. R5 – Extends depot repair warranty service period to five years.

Opt. S1 – Uplifts standard one-year warranty service of mainframe and installed modules to on-site service.

Opt. S3 – Uplifts Opt. C3 and/or R3 of mainframe and installed modules to on-site service (must be ordered with Opt. C3 and/or R3).

Opt. C3 – Three years of calibration service (includes initial calibration and two annual calibrations).

Opt. C5 – Five years of calibration service (includes initial calibration and four annual calibrations).

Opt. D1 – Add calibration test data report.

Opt. D3 – Provides test data for each calibration (must be ordered with Opt. C3).

Opt. D5 – Provides test data for each calibration (must be ordered with Opt. C5).

Contact Tektronix:

ASEAN Countries & Pakistan (65) 6356 3900

Australia & New Zealand (65) 6356 3900

Austria +43 2236 8092 262

Belgium +32 (2) 715 89 70

Brazil & South America 55 (11) 3741-8360

Canada 1 (800) 661-5625

Central Europe & Greece +43 2236 8092 301

Denmark +45 44 850 700

Finland +358 (9) 4783 400

France & North Africa +33 (0) 1 69 86 80 34

Germany +49 (221) 94 77 400

Hong Kong (852) 2585-6688

India (91) 80-2275577

Italy +39 (02) 25086 1

Japan (Sony/Tektronix Corporation) 81 (3) 3448-3111

Mexico, Central America & Caribbean 52 (5) 666-6333

The Netherlands +31 (0) 23 569 5555

Norway +47 22 07 07 00

People's Republic of China 86 (10) 6235 1230

Poland +48 (0) 22 521 53 40

Republic of Korea 82 (2) 528-5299

Russia, CIS & The Baltics +358 (9) 4783 400

South Africa +27 11 254 8360

Spain +34 (91) 372 6055

Sweden +46 8 477 6503/4

Taiwan 886 (2) 2722-9622

United Kingdom & Eire +44 (0) 1344 392400

USA 1 (800) 426-2200

For other areas contact Tektronix, Inc. at: 1 (503) 627-7111

Updated 23 January 2002



For the most up-to-date product information visit our web site at www.tektronix.com

Copyright © 2002, Tektronix, Inc. All rights reserved. Tektronix products are covered by U.S. and foreign patents, issued and pending. Information in this publication supersedes that in all previously published material. Specification and price change privileges reserved. TEKTRONIX and TEK are registered trademarks of Tektronix, Inc. All other trade names referenced are the service marks, trademarks or registered trademarks of their respective companies.

01/02 HB/XBS

52W-15056-0